



PRI Evaluation Report

PRI ER 476E01

Issue Date: 11/09/2020

Last Revision: Original Issue

This Report is Reviewed Annually

Visit: pri-group.com for current status.

Report Holder:

IKO Industries Ltd.

1600 - 42nd Avenue S.E.,
Calgary, Alberta T2G 5B5
www.iko.com

IKO Industries Inc.

6 Denny Road, Suite 200
Wilmington, Delaware 19809

SCOPE

Subject: Asphalt Shingles

CSI MasterFormat®:

DIVISION: 07 00 00 – THERMAL AND MOISTURE PROTECTION
Sub-level 2: 07 30 00 – Steep Slope Roofing
Sub-level 3: 07 31 00 – Shingles and Shakes
Sub-level 4: 07 31 13 – Asphalt Shingles

Code References:

- 2018, 2015, 2012, and 2009 International Building Code® (IBC)
- 2018, 2015, 2012, and 2009 International Residential Code® (IRC)

Properties Evaluated:

- External Fire Exposure (ASTM E108, ANSI/UL790)
- Wind Resistance (ASTM D3161; ASTM D7158)
- Physical Properties (ASTM D3462)
- Impact Resistance (FM 4473)

Evidence Submitted:

- Test report(s) indicating compliance with ASTM E108 and/or ANSI/UL790 and/or CAN/ULC S107
- Test report(s) indicating compliance with ASTM D3161
- Test report(s) indicating compliance with ASTM D7158
- Test report(s) indicating compliance with ASTM D3462
- Test report(s) indicating compliance with FM 4473
- Quality Documentation
- Manufacturer’s Drawings and Installation Instructions

Manufacturing Locations:

<u>Factory ID</u>	<u>Location</u>
SU	850 West Front Street Sumas, WA 98295-9634
WN	120 Hay Road Wilmington, DE 19809
KE	235 West South Tec Dr. Kankakee, IL 60901
SY	1708 Sylacauga – Fayetteville Highway Sylacauga, AL 35151
HL	1001 IKO Way Hillsboro, TX 76645
HY	1451 Spence Ave Hawkesbury, ON K6A 3T4
CY	1600 - 42nd Avenue S.E. Calgary, AB T2G 5B5
CRC	560 Commissioners Street Toronto, ON M4M 1A7
IG	87 Orenda Road Brampton, ON L6W 1V7



PRODUCT DESCRIPTIONS and APPLICATIONS

Products:

IKO Crowne Slate
IKO Armourshake
IKO Royal Estate
IKO Dynasty
IKO Nordic
IKO Cambridge
IKO Roofshake HW
IKO Marathon Plus AR
IKO Hip & Ridge 12
IKO Hip & Ridge Plus
IKO Hip and Ridge
IKO Armour Starter
IKO Leading Edge Plus
CRC Superglass
CRC Biltmore
CRC Regency

IKO Dynasty	KE, SU, HY, HL, CY	13- ³ / ₄ " x 40- ⁷ / ₈ "
IKO Nordic	KE, HL	13- ³ / ₄ " x 40- ⁷ / ₈ "
IKO Cambridge	CY, HY, HL, SU, SY, WN, CRC, KE	13- ³ / ₄ " x 40- ⁷ / ₈ "
IKO Roofshake HW	SU	13- ³ / ₄ " x 40- ⁷ / ₈ "
CRC Biltmore	CRC, CY, HY, KE, SU	13- ³ / ₄ " x 40- ⁷ / ₈ "
CRC Regency	CY, HY, KE	13- ³ / ₄ " x 40- ⁷ / ₈ "

Product Descriptions:

IKO®/CRC® asphalt shingles are roof covering materials that conform to the following properties when installed as instructed in this report. The products consist of three-tab shingles, laminated shingles, starter strip shingles, hip and ridge shingles, and ice and water membranes.

Three-tab (single-layer): Three-tab, fiberglass reinforced shingles. The shingles are manufactured with a single fiberglass mat, coated on both sides with asphalt, and surfaced on the weather-exposed side with ceramic mineral granules.

Product:	Factory IDs:	Dimensions:
IKO Marathon Plus AR	CRC, CY, HL, KE, SU, HY, SY	13- ¹ / ₄ " x 39- ³ / ₈ "
CRC Superglass	CY, HY, CRC	13- ¹ / ₄ " x 39- ³ / ₈ "

Laminated (multi-layer): Laminated, fiberglass reinforced shingles. The shingles are manufactured with 2 layers of fiberglass mat coated with asphalt on both sides, and surfaced on the weather-exposed side with mineral granules.

Product:	Factory IDs:	Dimensions:
IKO Crowne Slate	CRC	13- ¹ / ₄ " x 39- ¹ / ₂ "
IKO Armourshake	SU	18- ³ / ₁₆ " x 37- ³ / ₈ "
IKO Royal Estate	CRC	13- ¹ / ₄ " x 40"

Accessory (hip and ridge): Single-layer asphalt impregnated, asphalt hip and ridge shingles. Shingles are scored for easy separation and are surfaced with mineral granules.

Product:	Factory IDs:	Dimensions:
IKO Hip and Ridge	SU	13- ¹ / ₄ " x 39- ³ / ₈ "
IKO Hip & Ridge 12	SY, KE	13- ¹ / ₄ " x 36"
IKO Hip & Ridge Plus	CY	13- ¹ / ₄ " x 39- ³ / ₈ "

Accessory (starter strip): Prefabricated starter course shingles. Shingles are scored for easy separation.

Product:	Factory IDs:	Dimensions:
IKO Leading Edge Plus	HY	15- ³ / ₄ " x 40- ⁷ / ₈ "
IKO Armour Starter	SU	13- ¹ / ₄ " x 39- ³ / ₈ "



Fire Classification:

When installed on new construction in accordance with this report and the IKO®/CRC® installation instructions, the IKO®/CRC® asphalt shingles are Class A fire classification roof covering in accordance with ASTM E108, and/or ANSI/UL790, and/or CAN/ULC S107 and qualify for use under the following code:

- 2018, 2015, 2012, and 2009 *IBC* Section 1505
- 2018, 2015, 2012, and 2009 *IRC* Section R902

When the shingles are installed over existing roof coverings, the fire classification is maintained.

Wind Resistance:

IKO®/CRC® asphalt shingles covered under this report have been tested for wind resistance in accordance with the following test methods:

Shingles tested in accordance with ASTM D3161 are classified as Class F and qualify for use under the exception to the following code:

- 2018 and 2015 *IBC* Section 1504.1.1
- 2012 and 2009 *IBC* Section 1507.2.7.1
- 2018, 2015, 2012, and 2009 *IRC* Section R905.2.4.1

Shingles tested in accordance with ASTM D7158 are classified as Class H and qualify for use in locations as shown in the following code:

- 2018 and 2015 *IBC* Section 1504.1.1
- 2012 and 2009 *IBC* Section 1507.2.7.1
- 2018, 2015, 2012 and 2009 *IRC* Section R905.2.4.1

Where the maximum allowable stress design wind speed is 150 mph (67 m/s) or less with exposure category of B or C (ASCE 7) and a maximum building height of 60 feet (18.3 m).

Impact Resistance:

IKO® Nordic shingles covered under this report have been tested for impact resistance in accordance with FM 4473 Class 4.

Physical Properties:

IKO®/CRC® asphalt shingles covered under this report have been tested for physical properties in accordance with ASTM D3462 and qualify for use under the following code:

- 2018 *IBC* Section 1507.2.4
- 2015, 2012, and 2009 *IBC* Section 1507.2.5
- 2018, 2015, 2012, and 2009 *IRC* Section R905.2.4



INSTALLATION – GENERAL

IKO®/CRC® asphalt shingles must be installed in accordance with the applicable code, this report, and the manufacturer's published installation instructions which must be available at all times on the jobsite during installation. The shingles must be installed in accordance with the following code as applicable, except as noted in this report:

- 2018, 2015, 2012, and 2009 *IBC* Section 1507.2
- 2018, 2015, 2012, and 2009 *IRC* Section R905.2

Deck:

The roof deck must be code-complying minimum $\frac{3}{8}$ -inch thick (9.5 mm) exterior plywood complying with DOC PS-1, minimum $\frac{7}{16}$ -inch thick (11.1 mm) OSB rated sheathing complying with DOC PS-2, or solid sheathing using minimum nominal 1 by 6 lumber. Roof sheathing shall comply with the following code:

- 2018, 2015, 2012, and 2009 *IBC* Section 1507.2.1
- 2018, 2015, 2012, and 2009 *IRC* Section R905.2.1

Underlayment and Ice Barriers:

Underlayment must comply with ASTM D226, ASTM D4869, or ASTM D6757 as specified in the following code:

- 2018 *IBC* Section 1507.2.3
- 2015, 2012, and 2009 *IBC* Section 1507.2.3 and 1507.2.4
- 2018, 2015, 2012, and 2009 *IRC* Section R905.2.3

Underlayment application must be in accordance with the following code, as applicable:

- 2018 *IBC* Section 1507.2.3
- 2015, 2012, and 2009 *IBC* Section 1507.2.8
- 2018, 2015 *IRC* Section R905.2.3
- 2012, and 2009 *IRC* Section R905.2.7

When used as an underlayment under shingles described in this report, self-adhering polymer modified bitumen sheet must comply with ASTM D1970.

In areas where there has been a history of ice forming along the eaves causing a backup of water, an ice barrier must be provided in accordance with the following code, as applicable:

- 2018 *IBC* Section 1507.2.7
- 2015, 2012, and 2009 *IBC* Section 1507.2.8.2
- 2018, 2015 *IRC* Section R905.2.7
- 2012 and 2009 *IRC* Section R905.2.7.1

Fasteners:

Fasteners must comply with ASTM F1667 and be minimum No. 12 gage (0.105 inch), $\frac{3}{8}$ -inch diameter head, galvanized,

stainless steel, aluminum or copper shank roofing nails. Fasteners must penetrate the deck a minimum of $\frac{3}{4}$ inch, or through the deck, where the deck is less than $\frac{3}{4}$ inch thick. Fasteners and Installation must be in accordance with the following code, as applicable:

- 2018 *IBC* Section 1507.2.5 and 1507.2.6
- 2015, 2012, and 2009 *IBC* Section 1507.2.6 and 1507.2.7
- 2018, 2015, 2012, and 2009 *IRC* Section R905.2.5 and R905.2.6

Asphalt Cement:

Asphalt cement must comply with ASTM D4586.

Flashings:

Base and cap flashing must be minimum nominal 0.019-inch thick corrosion-resistant metal. Base and cap flashing must be installed as described in the following code:

- 2018 *IBC* Section 1507.2.8.1
- 2015, 2012, and 2009 *IBC* Section 1507.2.9.1
- 2018, 2015, 2012, and 2009 *IRC* Section R905.2.8.1 and R905.2.8.3

Valley flashing must be provided. Valley linings must comply with the following code, as applicable:

- 2018 *IBC* Section 1507.2.8.2
- 2015, 2012, and 2009 *IBC* Section 1507.2.9.2
- 2018, 2015, 2012, and 2009 *IRC* Section R905.2.8.2

A drip edge flashing must be provided at eaves and rake edges. Drip edge must be installed as described in the following code:

- 2018 *IBC* Section 1507.2.8.3
- 2015, 2012, and 2009 *IBC* Section 1507.2.9.3
- 2018, 2015, and 2012 *IRC* Section R905.2.8.5

Other flashings and construction details must be installed in accordance with manufacturer's published installation instructions and applicable code(s).

Reroofing:

Reroofing is allowable. Reroofing shall be subject to the provisions and limitations of the following codes:

- 2018 and 2015 *IBC* Section 1511
- 2012 and 2009 *IBC* Section 1510
- 2018 and 2015 *IRC* Section R908
- 2012 and 2009 *IRC* Section R907



INSTALLATION – ASPHALT SHINGLES

Starter Shingles:

The **Leading Edge Plus** starter strip must be separated along perforation into two parts prior to installation. Install Leading Edge Plus starter shingle according to the published installation instructions with the granule side up and the factory installed sealant adjacent to the eaves. Remove approximately 20 inches from the first starter shingle and align along eave and rake edges (Note: Remove 4 inches in **Armourshake** applications). The starter strip should overhang the rake edge and eaves by $\frac{1}{4}$ to $\frac{3}{4}$ inch and be fastened to the roof deck with nails located 3 to 4 inch from the eave edge, 4 nails per starter strip, and 1 inch in from each end (Figure 1).

The **Armour Starter** shingle (Required in **Armourshake** applications) must be applied over a base layer of **Leading Edge Plus** that is fastened per manufacturers published installation instructions with 4 nails located 1 inch above the sealant strip and spaced 1 inch in from each edge and midway between those points. For **Armour Starter**, remove approximately 20 inches from the first shingle and align along eave and rake edges. The **Armour Starter** shingle shall be applied per manufacturers published installation instructions and flush to the rake and eave edges of the underlying **Leading Edge Plus** starter. The **Armour Starter** is then fastened to the roof deck with four nails located just above the area of colored granules, approximately 1 inch in from each end, and midway between those points (See Figure 1).

Figure 1 – Starter Shingle Placement

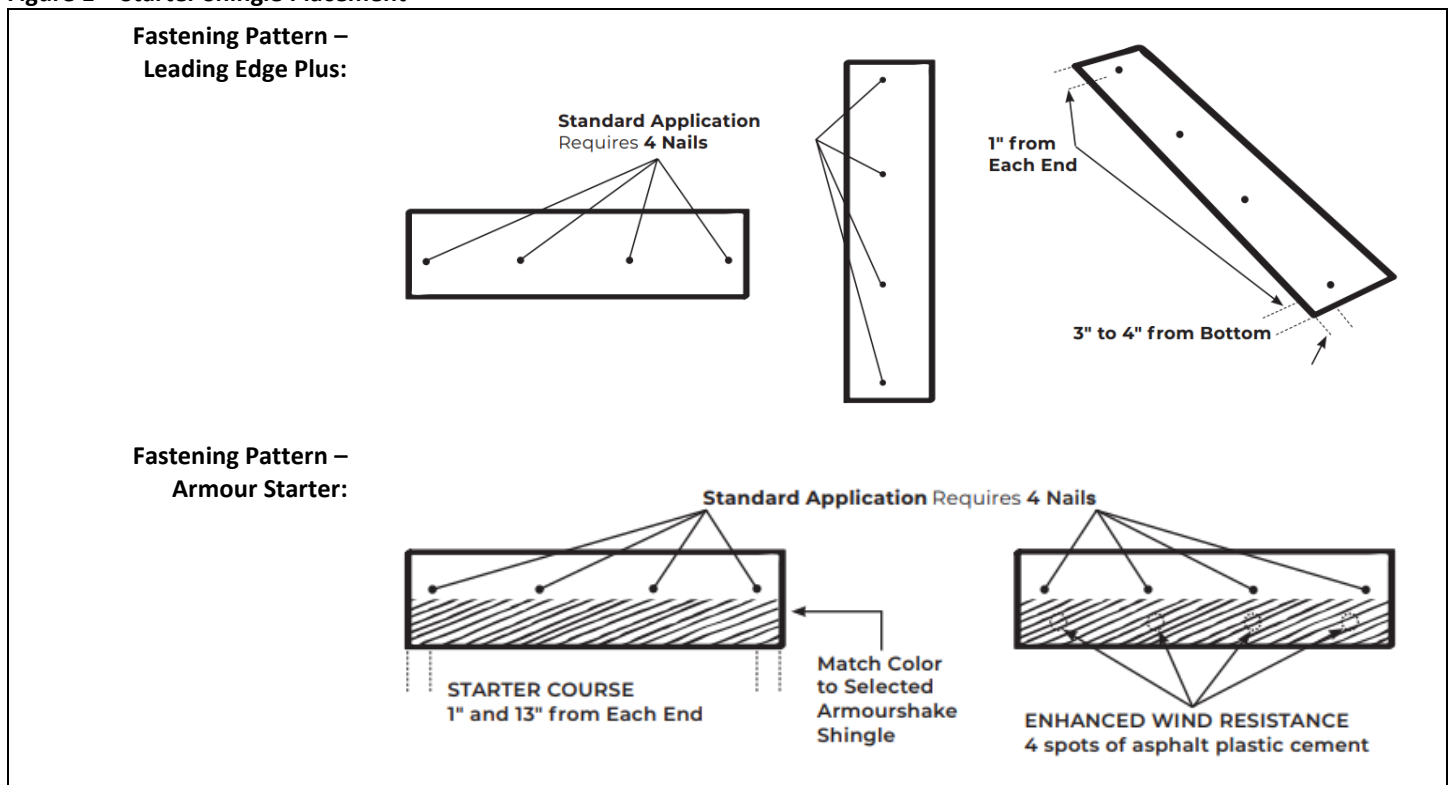



Field Shingles:

Marathon Plus AR and **CRC Superglass** are self-sealing and have thermal sealing adhesive buttons spaced 1 inch apart at the centerline of the shingle, 6^{-5/8} inches up from the butt edge. **Marathon Plus AR** and **Superglass** must have a maximum exposure of 5^{-5/8} inches and the location of the nail line is at 6^{-1/8} inches.

For roof slopes of 2:12 up to 21:12 (16.67% or 9° up to 175% or 60°), use a minimum of four (4) fasteners per shingle. For roof slopes over 21:12 (175% or 60°), use a minimum of six (6) fasteners per shingle. Fasteners must be placed on the fastener line. (See Figure 2)

The first course of field shingles must be installed over a starter course. Apply first course starting with a full shingle, aligned even with starter. Subsequent shingle courses must be installed with vertical joint offsets from adjacent courses. Reference published installation instructions for details.

Note: In colder climates or wind regions where it is questionable whether the thermal-sealing adhesive will activate to seal the shingles, the shingles can be hand-sealed. A 1 inch diameter spot of asphalt cement should be placed at the center (1^{-1/2} inches up from the bottom edge) of each tab. Overlaying shingles are sealed by having them embedded in the cement spots. For roof slopes over 21:12 (175% or 60°), hand-sealing is required. Refer to the hand-sealing guidelines in the published installation instructions. The shingles must be hand-sealed to the satisfaction of the code official.

Figure 2 – Low Slope Fastener Pattern

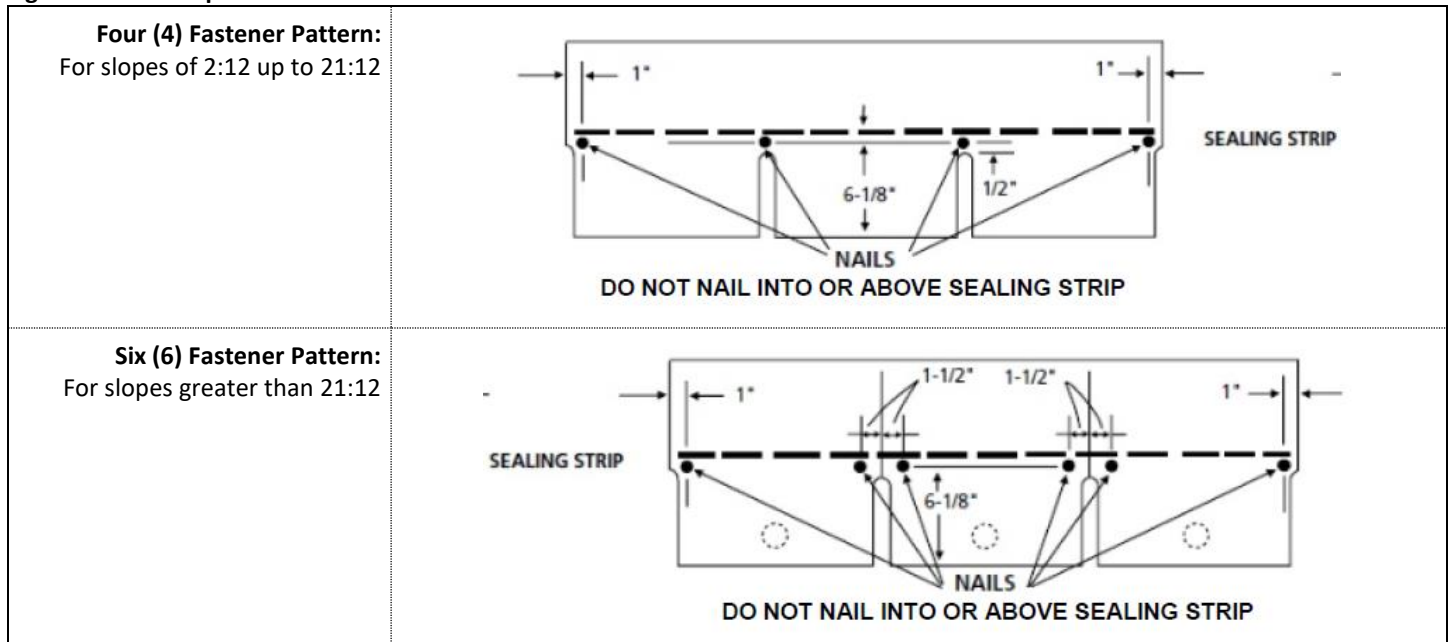



Cambridge, CRC Biltmore, and RoofShake HW are self-sealing with thermal sealing adhesive buttons above the shingle butt on the unexposed side. **Cambridge, CRC Biltmore, and Roofshake HW** must have a maximum exposure of 5-7/8 inches.

For roof slopes of 2:12 up to 21:12 (16.67% or 9° up to 175% or 60°), use a minimum of four (4) fasteners per shingle. For roof slopes over 21:12 (175% or 60°), use a minimum of six (6) fasteners per shingle and seal each shingle with three (3) 1 inch diameter spots of roofing cement. Fasteners must be placed on the fastener line. (See Figure 3)

The first course of field shingles must be installed over a starter course. Apply first course starting with a full shingle, aligned even with starter. Subsequent shingle courses must be installed with vertical joint offsets from adjacent courses. 10 inch offsets are suggested. Reference published installation instructions for details.

Note: In colder climates or wind regions where it is questionable whether the thermal-sealing adhesive will activate to seal the shingles, the shingles can be hand-sealed. Three (3) 1 inch diameter spots of asphalt cement per shingle should be equally spaced along a line 6-1/4 inches below the top edge of the previous course of shingles. Overlaying shingles are sealed by having them embedded in the cement spots. For roof slopes over 21:12 (175% or 60°), hand-sealing is required. Refer to the hand-sealing guidelines in the published installation instructions. The shingles must be hand-sealed to the satisfaction of the code official.

Figure 3 - Low Slope Fastener Pattern – Cambridge Shingle, CRC Biltmore Shingle, RoofShake HW Shingle

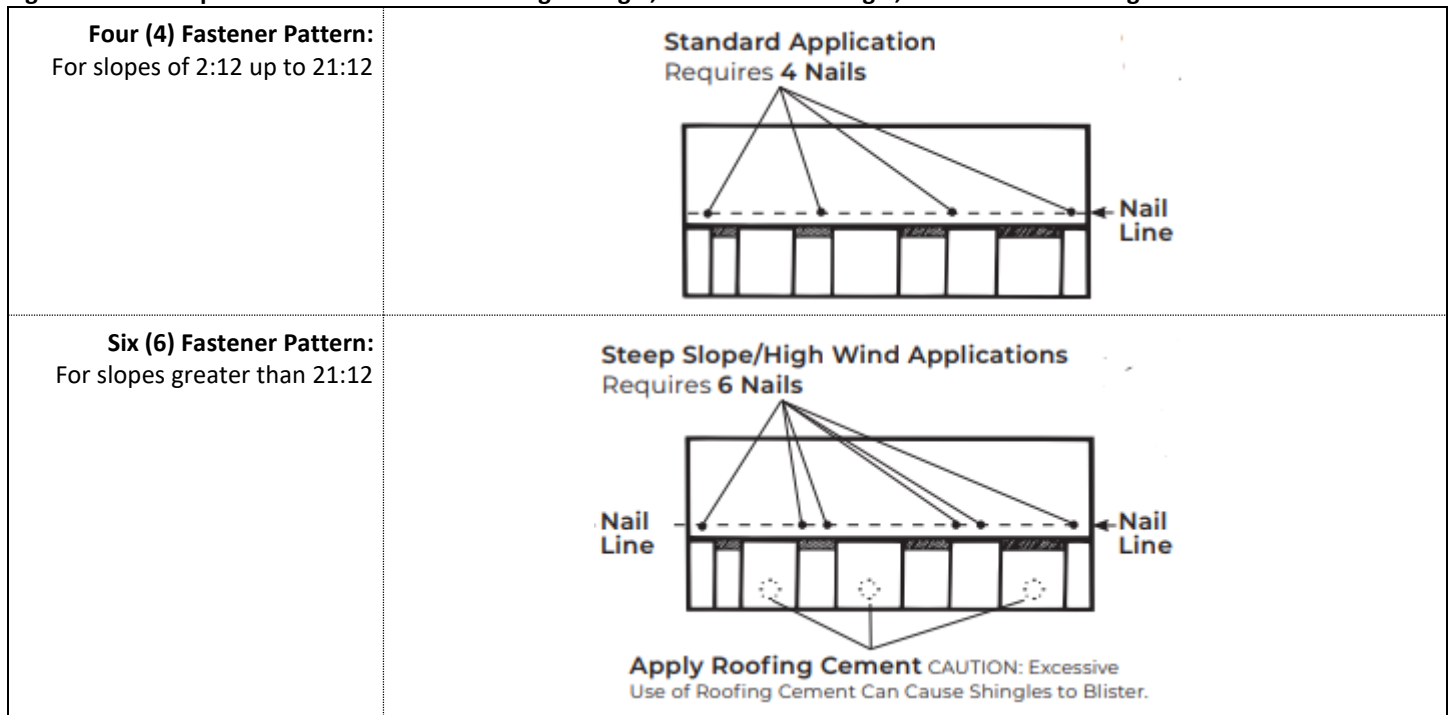



Dynasty, CRC Regency, and Nordic are self-sealing with thermal sealing adhesive buttons above the shingle butt on the unexposed side. **Dynasty, CRC Regency, and Nordic** must have a maximum exposure of $5\text{-}\frac{7}{8}$ inches.

For roof slopes of 2:12 up to 21:12 (16.67% or 9° up to 175% or 60°), use a minimum of four (4) fasteners per shingle. For roof slopes over 21:12 (175% or 60°), use a minimum of six (6) fasteners per shingle and seal each shingle with three (3) 1 inch diameter spots of roofing cement. Fasteners must be placed on the fastener line. (See Figure 4)

The first course of field shingles must be installed over a starter course. Apply first course starting with a full shingle, aligned even with starter. Subsequent shingle courses must be installed with vertical joint offsets from adjacent courses. 10 inch offsets are suggested. Reference published installation instructions for details.

Note: In colder climates or wind regions where it is questionable whether the thermal-sealing adhesive will activate to seal the shingles, the shingles can be hand-sealed. Three (3) 1 inch diameter spots of asphalt cement per shingle should be equally spaced along a line $6\text{-}\frac{1}{4}$ inches below the top edge of the previous course of shingles. Overlaying shingles are sealed by having them embedded in the cement spots. For roof slopes over 21:12 (175% or 60°), hand-sealing is required. Refer to the hand-sealing guidelines in the published installation instructions. The shingles must be hand-sealed to the satisfaction of the code official.

Figure 4 - Low Slope Fastener Pattern – Dynasty Shingle, CRC Regency Shingle, Nordic Shingle

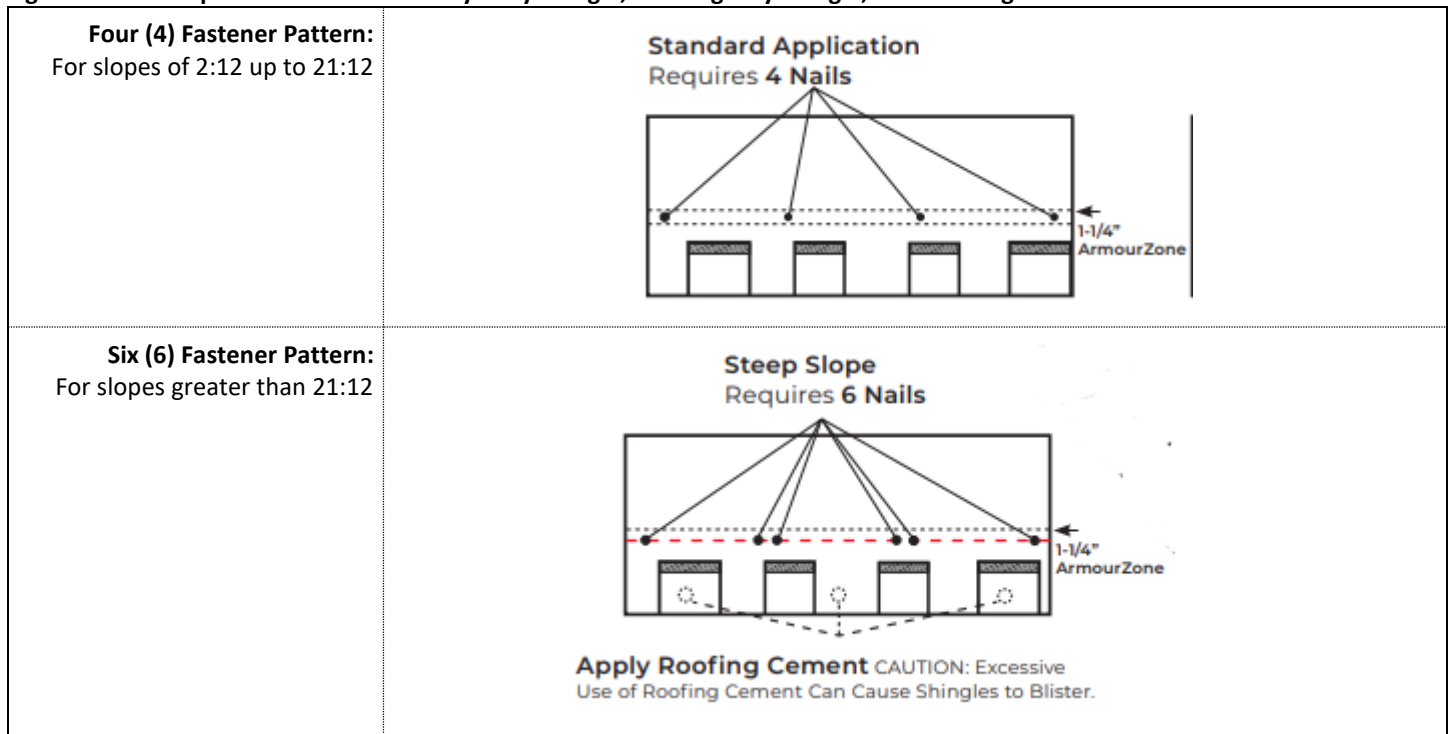



Crowne Slate is self-sealing with thermal sealing adhesive buttons above the shingle butt on the unexposed side. **Crowne Slate** must have a maximum exposure of 10 inches.

For roof slopes of 2:12 up to 21:12 (16.67% or 9° up to 175% or 60°), use a minimum of five (5) fasteners per shingle. For roof slopes over 21:12 (175% or 60°), use a minimum of eight (8) fasteners per shingle and seal each shingle with four (4) plus one (1) 1 inch diameter spots of roofing cement; the plus one (1) spot is located on top of the overlap area. Fasteners must be placed on the fastener line. (See Figure 5)

The first course of field shingles must be installed over a starter course. For the first course, remove one full tab from the left end of a full shingle and apply aligned even with starter along eave and rake edges. Subsequent shingle courses must be installed with vertical joint offsets from adjacent courses. Half tab offsets are suggested. Reference published installation instructions for details.

Note: In colder climates or wind regions where it is questionable whether the thermal-sealing adhesive will activate to seal the shingles, the shingles can be hand-sealed. Four (4) plus one (1) 1 inch diameter spots of asphalt cement per shingle should be equally spaced along a line 1-¹/₄ inches below the top edge of the previous course of shingles. Overlaying shingles are sealed by having them embedded in the cement spots. For roof slopes over 21:12 (175% or 60°), hand-sealing is required. Refer to the hand-sealing guidelines in the published installation instructions. The shingles must be hand-sealed to the satisfaction of the code official.

Figure 5 - Low Slope Fastener Pattern – Crown Slate Shingle

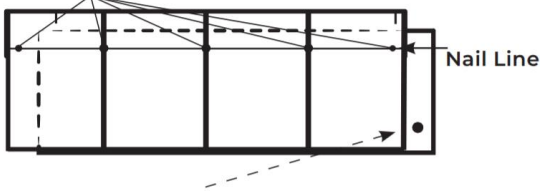
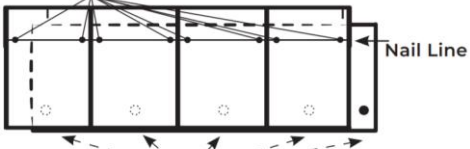
<p>Five (5) Fastener Pattern: For slopes of 2:12 up to 21:12</p>	<p>Standard Application Requires 5 Nails</p>  <p>OPTIONAL: For optimal wind resistance, add a spot of cement here at the time of installation.</p>
<p>Eight (8) Fastener Pattern: For slopes greater than 21:12</p>	<p>Steep Slope/High Wind Applications Requires 8 Nails</p>  <p>Apply Roofing Cement CAUTION: Excessive use of roofing Cement can cause shingles to blister.</p>



Royal Estate is self-sealing with thermal sealing adhesive buttons above the shingle butt on the unexposed side. **Royal Estate** must have a maximum exposure of 5-⁵/₈ inches.

For roof slopes of 2:12 up to 21:12 (16.67% or 9° up to 175% or 60°), use a minimum of four (4) fasteners per shingle. For roof slopes over 21:12 (175% or 60°), use a minimum of six (6) fasteners per shingle and seal each shingle with three (3) 1 inch diameter spots of roofing cement. Fasteners must be placed on the fastener line. (See Figure 6)

The first course of field shingles must be installed over a starter course. Apply first course starting with a full shingle, aligned even with starter along eave and rake edges. Subsequent shingle courses must be installed with vertical joint offsets from adjacent courses. A repeating pattern of full shingle followed by 8-³/₄ inch, 16-⁵/₈ inch, and 30-⁵/₈ inch offsets is suggested. Reference published installation instructions for details.

Note: In colder climates or wind regions where it is questionable whether the thermal-sealing adhesive will activate to seal the shingles, the shingles can be hand-sealed. Three (3) 1 inch diameter spots of asphalt cement per shingle should be equally spaced along a line 6-¹/₄ inches below the top edge of the previous course of shingles. Overlaying shingles are sealed by having them embedded in the cement spots. For roof slopes over 21:12 (175% or 60°), hand-sealing is required. Refer to the hand-sealing guidelines in the published installation instructions. The shingles must be hand-sealed to the satisfaction of the code official.

Figure 6 - Low Slope Fastener Pattern – Royal Estate Shingle

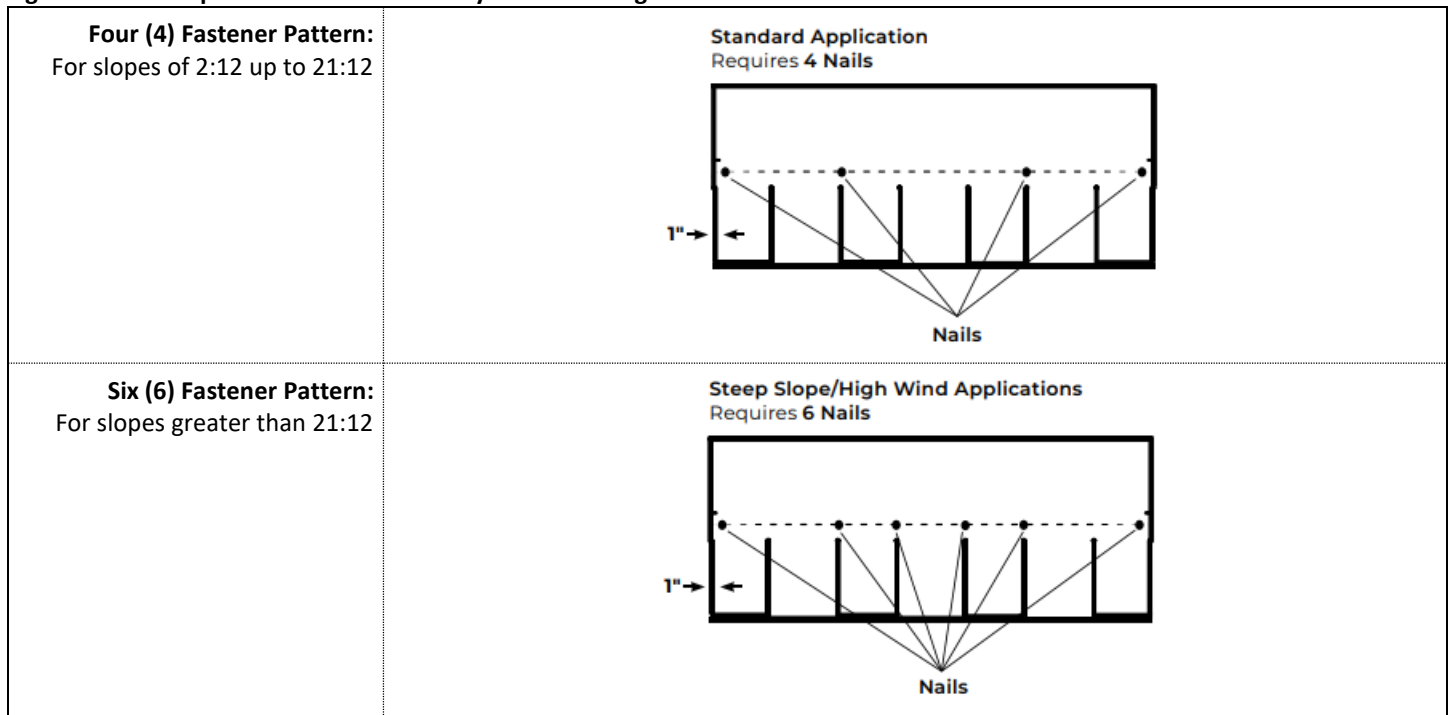



Armourshake is self-sealing with thermal sealing adhesive buttons above the shingle butt on the unexposed side. **Armourshake** must have a maximum exposure of 5-1/2 inches.

For roof slopes of 2:12 up to 21:12 (16.67% or 9° up to 175% or 60°), use a minimum of five (5) fasteners per shingle. For roof slopes over 21:12 (175% or 60°), use a minimum of six (6) fasteners per shingle and seal each shingle with three (3) 1 inch diameter spots of roofing cement. Fasteners must be placed on the fastener line. (See Figure 7)

Armourshake requires two (2) courses of starter shingles, **Leading Edge Plus** plus **Armour Starter**. The first course of field shingles must be installed over **Armour Starter**. Apply first course starting with a full shingle, aligned even with starter along eave and rake edges. Subsequent shingle courses must be installed with vertical joint offsets from adjacent courses. Second course is a 5-5/8 inch offset. Third course is a 11-1/4 inch offset. Fourth course is a 16-7/8 inch offset. Fifth course is a 22-1/2 inch offset. Sixth course is a 28-1/2 inch offset. Succeeding course repeat pattern. Reference published installation instructions for details.

Note: In colder climates or wind regions where it is questionable whether the thermal-sealing adhesive will activate to seal the shingles, the shingles can be hand-sealed. Three (3) 1 inch diameter spots of asphalt cement per shingle should be placed beneath each shake cut out. Overlaying shingles are sealed by having them embedded in the cement spots. For roof slopes over 21:12 (175% or 60°), hand-sealing is required. Refer to the hand-sealing guidelines in the published installation instructions. The shingles must be hand-sealed to the satisfaction of the code official.

Figure 7 - Low Slope Fastener Pattern – Armourshake Shingle

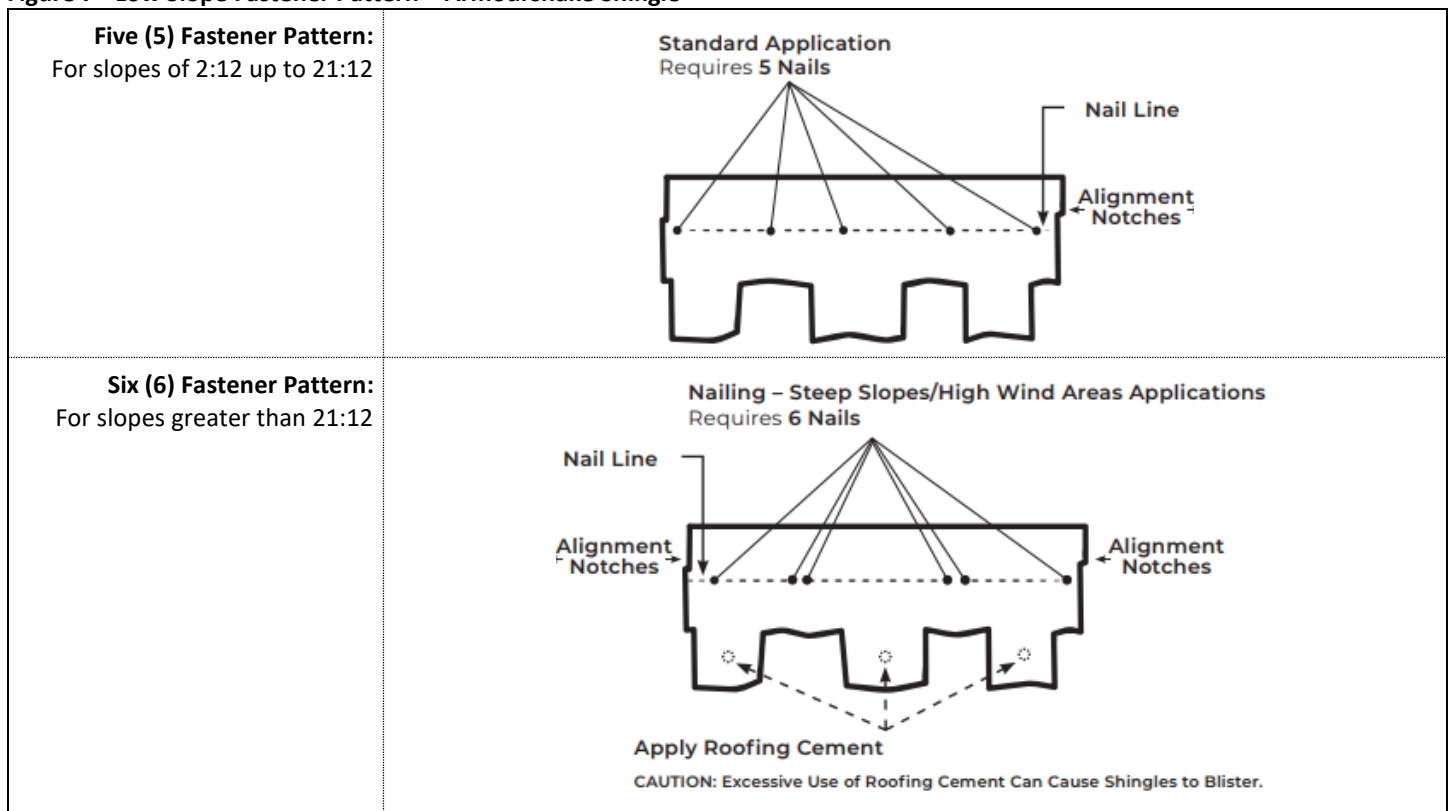



Hip and Ridge Shingles:

Hip and Ridge, Hip & Ridge Plus, and Hip & Ridge 12: Separate shingle into pieces by bending at perforation marks. **Hip and Ridge** separates into four (4) pieces. **Hip & Ridge Plus** and **Hip & Ridge 12** separate into three (3) pieces. Pieces may be optionally trimmed on a 1 inch taper in the headlap portion. Maximum exposure to the weather must be 5-⁵/₈ inches.

Install laminated shingles per manufacturers published installation instructions. Use two fasteners per piece. Fasten each shingle with one fastener on each side, placed 6-¹/₄ inch from the exposed end and 1 inch up from the edge. Cover the exposed nail heads of the final shingle with asphalt cement. (See Figure 8)

Figure 8 – Hip and Ridge Shingle Placement

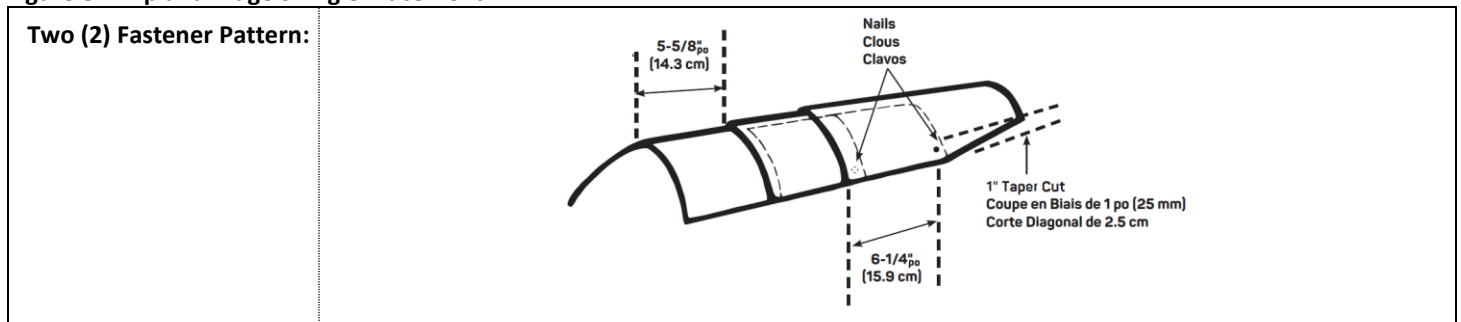



CONDITIONS OF USE & IDENTIFICATION

The IKO®/CRC® Asphalt Shingles described in this report comply with, or are suitable alternatives to, the codes listed in this report, subject to the following conditions:

- The products as well as the installation methods must be in compliance with the applicable code, this report, and the installation instruction provided by the manufacturer. If the manufacturer's installation instructions differ from what is listed in this report, this report governs.
- This report does not supersede the local jurisdiction regulations and the final approval of the building products, materials, or systems in this report is the responsibility of the authorities having jurisdiction.
- This report is only valid if the product(s) and/or the referenced documentation/codes related to the products do not change. If there is a change in product(s) and/or the referenced documentation/codes related to the products, PRI Construction Materials Technologies, LLC must be informed and further action may be necessary to revalidate this report.
- This report, in its entirety, must be available at job sites upon request by the user or for inspection by the Building Official. A copy of this report in full shall be provided by the manufacturer or its distributors.
- The products are identified by marks bearing the report holder's name, the manufacture location, the product name, and the Seal of PRI Validation Program for Building Materials. The Seal shall indicate, at a minimum, the following:
 - a. ASTM E108 – Class A
 - b. ASTM D3161 – Class F
 - c. ASTM D7158 – Class H
 - d. ASTM D3462
- The products are manufactured at the locations listed in this report and are manufactured under a quality control program with inspections and/or surveillance by PRI Construction Materials Technologies, LLC.
- This report is a supplement to product certification. The products listed herein must be certified separately under the PRI Validation Program for Building Products. This report alone is not a product certification and requires separate product certification under the PRI Validation Program for Building Products to be valid.
- The current status of this report as well as a directory of certified products, including supplemental PRI Evaluation Reports, can be found at pri-group.com.

© 2019 PRI Construction Materials Technologies, LLC

This PRI Evaluation Report is for the exclusive use by the Client with which a signed agreement was made with PRI Construction Materials Technologies, LLC. PRI Construction Materials Technologies, LLC is only responsible and/or liable for the terms and conditions outlined in that signed agreement. Only the Client has authority to distribute or authorize distribution of the report in its entirety and they shall not do so in a misleading manner. Any loss, expense, or damage caused by the use of this report to any party, other than the Client in accordance with the agreement, is not the responsibility or fault of PRI Construction Materials Technologies, LLC. PRI Construction Materials Technologies, LLC has no financial interest, nor does it have intent to acquire financial interest, in the manufacture or the distribution of the product(s) listed in this report. PRI Construction Materials Technologies, LLC is not under the ownership, operation, or control of the manufacturer or the distributor of the product(s) listed in this report. PRI Construction Materials Technologies, LLC does not guarantee any representations or warranties on any product(s) or subjects contained in this report. This PRI Evaluation Report is an evaluation of building code and is in no way an endorsement or a recommendation for use for the product(s) listed within. All data utilized in support of this report comes from accredited laboratories that show compliance with ISO/IEC Standard 17025 by the International Accreditation Service (IAS) or by any other accreditation body that is a signatory to the International Laboratory Accreditation Cooperation (ILAC) Mutual Recognition Arrangement (MRA). The accuracy of any data that comes from an accredited laboratory that is not PRI Construction Materials Technologies, LLC is the responsibility of the publishing laboratory alone; PRI Construction Materials Technologies, LLC does not accept any responsibility for the accuracy of this data.